

Gonval INC.

HiTap SaVD Series Safe Vent Drain

- *Pressure Seal Bonnet*
- *Self-aligning Metal Seat*
- *Pressure-activated*
- *Solid Stellite Seat and Disc*
- *Replaceable Packing Chamber*



Now you can add a simple, single-weld, dual sealing system to Clampseal® Y-pattern valves to enhance leak-free performance and allow for fast, safe, environmentally-friendly venting and draining of piping systems.

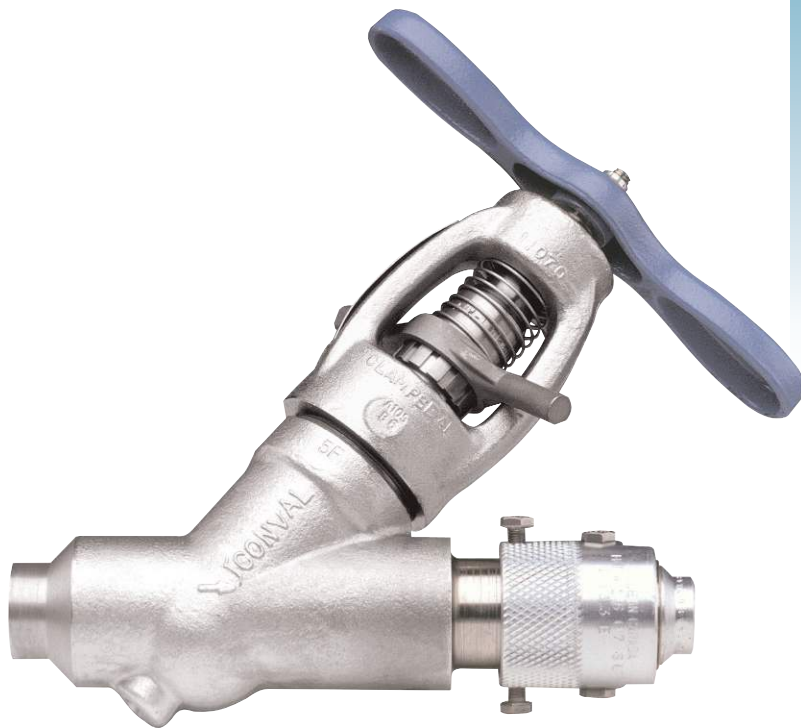

STANDARD SIZES

3/4" through 1 1/2"
Y Pattern; NPT, BW, SW Ends

PRESSURE RATING

150 - 600 ANSI
Models for higher pressures available

STANDARD MATERIALS

Stainless Steel A479-F316

STANDARD OPTIONS

Securing chain



DESIGN FEATURES

Pressure Seat Bonnet

Combined with self-aligning solid Stellite metal-to-metal seat and disc, this provides effective sealing without welds or gaskets.

Pressure Activated

Backseat requires low torque for total isolation of packing.

Replaceable Packing Chamber

The replaceable packing chamber allows for fast repacking of any valve.

Secondary Containment

The HILTAP metal-to-metal wedge, safety connector is the secondary containment, and includes two dynamic sealing surfaces, compact profile, ultra-safe residual pressure venting, quick connectability to a gravity drain hose. The coupling locks under line pressure.

Easy Installation and Cleaning

Just one weld is required to connect to pipe. Fitting is machined as an integral part of the valve. Locking threads are located outside wetted volumes. Valve-mounted couplings can be steam leaned and pressure-purged.

Single-Drip Depressurization

Safe depressurization is achieved in just one drip of fluid, significantly enhancing safety and environmental protection.

No-Spill Gravity Drainage

Hooking up the Safe Vent Drain with a matching HILTAP drainage pipe is safe, reliable, and quick. This minimizes downtime, labor, and environmental cleanup expense.

Meets OSHA Regulations

The HILTAP SaVD Series Safe Vent Drain replaces low pressure bull plug and screwed caps. Manufactured to ISO 9001-2000. Full material traceability, CRN registration available. Full technical specifications upon request.

SPECIFICATIONS

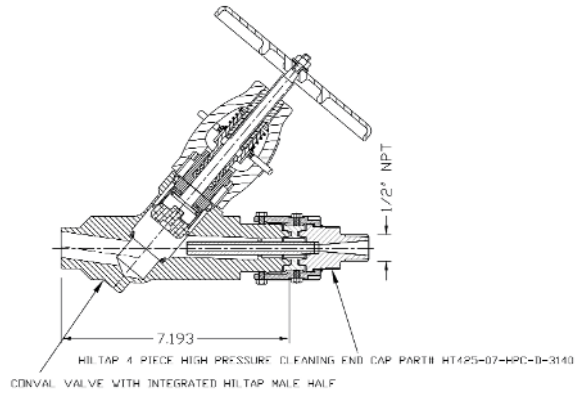
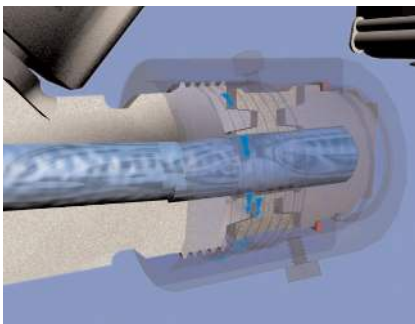
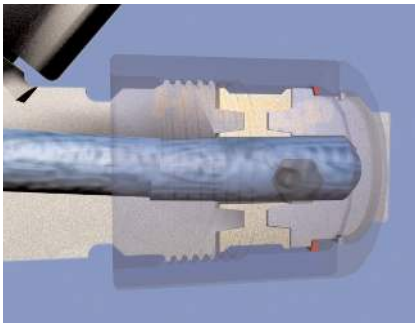

HT 425 for High Pressure Cleaning

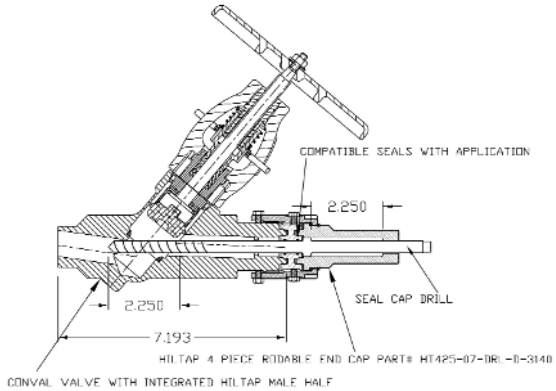

HT 425 with Rodable End Cap

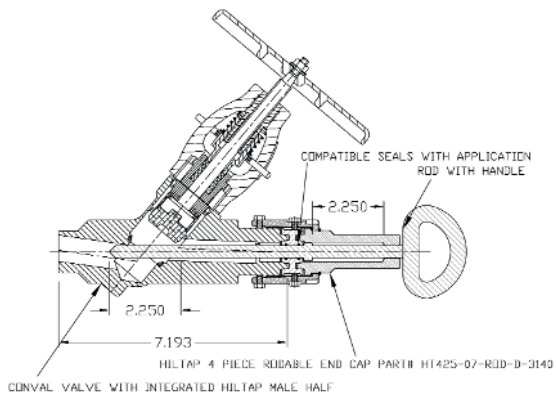

HT 425 with Rodable End Cap with Handle

LIST OF MATERIALS

Item	Qty	Description	Part No.	Rev	Material
1	1	3/4" Seal Cap Plain End	HT425-07-SC-D-2033	-	A350LF2
2	2	3/4" Retaining Ring	WS-134 (Smalley)	-	ANSI 302
3	1	3/4" Compensation ring	HT-07-CR-B-0479	-	SS304
4	1	3/4" Ferrule	HT425-07-FE-D-2033	-	A350LF2
5	1	3/4" Sleeve	HT425-07-8SA-D-2033	-	A350LF2
6	4	1/4" x 20 TPI Grade 5 bolt	HC-8	-	A449

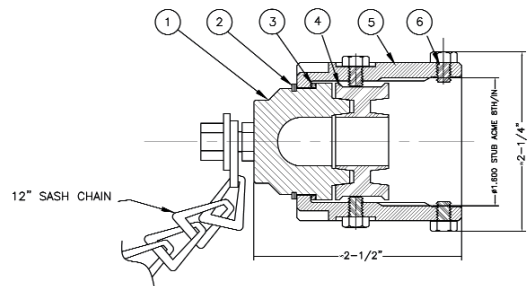

The Conval Story

In 1962, Mr. Chester Siver completed designs for a revolutionary line of high-pressure, forged steel valves. Hamilton Standard (now Hamilton Sunstrand), a division of United Technologies Corporation, was asked to use their then-new Electron Beam Welding technology for joining of parts into valves for subassemblies. Hamilton Standard became intrigued with the valve as an ideal application of the Electron Beam Welding technique, and negotiated a contract for the rights to manufacture and sell the valve. Mr. Siver served as manager of the valve project.



The first CLAMPSEAL® valves were introduced to the market by Hamilton Standard in 1964. However, in the mid-1960's, growing demand for the firm's popular aerospace products forced Hamilton Standard to make the decision to abandon its industrial products projects. The rights to the CLAMPSEAL valve reverted back to Mr. Siver. Since CLAMPSEAL valves were born in Connecticut, Mr. Siver founded "Conval" (short for Connecticut Valve) in 1967. Today, the valves are still manufactured in Connecticut, a state with a longstanding reputation for technological innovation and manufacturing excellence.

Conval is celebrating its 40th anniversary in 2007 with the launch of the new Camseal Ball Valve. Conval has grown into a leader in valves for the world's most demanding applications. We have a global team of experts to help to meet your most challenging needs. We invite you to contact us today.

High-pressure, high-temperature ball, bellows, bonnetless, check, gate, globe, throttling, and urea service valves for the world's most demanding applications.



1967-2007

Celebrating 40 years of excellence!

Thank you for your business.

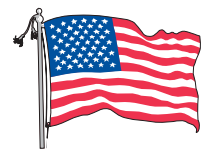

MADE IN USA

***ISO 9001 certified since
September 11, 1992***

Conval INC.

World Headquarters: 265 Field Road P.O. Box 1049, Somers, CT 06071-1049 USA

Phone (860) 749-0761 Fax (860) 763-3557

e-mail: sales@Conval.com www.Conval.com

Conval's policy is one of continuous development and improvement. Every effort is made to produce up-to-date literature but this catalog should not be regarded as an infallible guide to current specifications and does not form part of any contract. Conval reserves the right to make product improvements and changes without prior notice.