

Sampling Valves



SchuF 

SchuF Fetterolf Sampling Valve Range

SchuF Fetterolf offers a large range of sampling valve solutions. Our standard Model 32 sampling valves are available from stock for fast deliveries. We also offer custom-built solutions.

SchuF Sampling Valves are designed to simplify the extraction of samples from or the injection into tanks, reactors or pipelines and allow for long, trouble free service. They are non-clogging and dead space free.



FIRE-SAFE TESTED!

Sampling Valves – Technical Information

Technical Information:

Designs:

The SchuF Fetterolf Model 32 Series is available in standard sizes from stock for fast delivery:

Model 32FR “ROD SEAL®”:

The “ROD SEAL®” design embodies the self-cleaning, seatless valve principle. Only SchuF Fetterolf offers the feature of “Super-Closure”, utilizing spring-loaded components. Ideal for extended plungers for crust-breaking.

Model 32PG (Metal Seal):

This robust, metal seated sampling valve is ideal for high temperature applications and can be manufactured in certified, FIRE-SAFE versions. Immediate flow is achieved as soon as the crank handle is turned! The 32PG is also ideal for injecting media into piping or vessels, since there are no soft sealing rings exposed to the flow.

Model 32FG “RAM SEAL®”:

The patented “RAM SEAL®” design features replaceable seal rings for ease of maintenance. The combination of a metal compression ring and a soft PTFE seal ring allows the valve to deliver incredibly low leakage rates in a variety of services (gas and liquid) over a long period of time.

Features

- All Model 32 valves are rated to ASME 600.
- Crank handle manual operators are easy to use.
- The outlet branch is at 60 degrees.
- All valves have Leakage Class VI shut-off (100% tested).
- Cast yokes and bodies are of a robust design.

Materials of Construction:

All wetted parts and bodies can be manufactured in a variety of materials including:

- 316 stainless steel (standard)
- Titanium
- Nickel Alloys
- Alloy 20
- Monel
- Others available. We will also fabricate to your specifications.

Actuation:

- Manual (Crank Handle, Handwheel or Bevel Gears)
- Deadman’s Handle
- Pneumatic
- Others available

Options:

- Sample Bottles
- Integral Heating Jackets
- Flushing Ports
- Extended Rams and Bodies
- Various Inlet Connections, T-Pieces, Half-Couplings, etc.

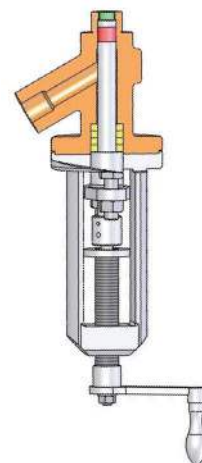

Model 32FR "Rod Seal"® Sampling Valve

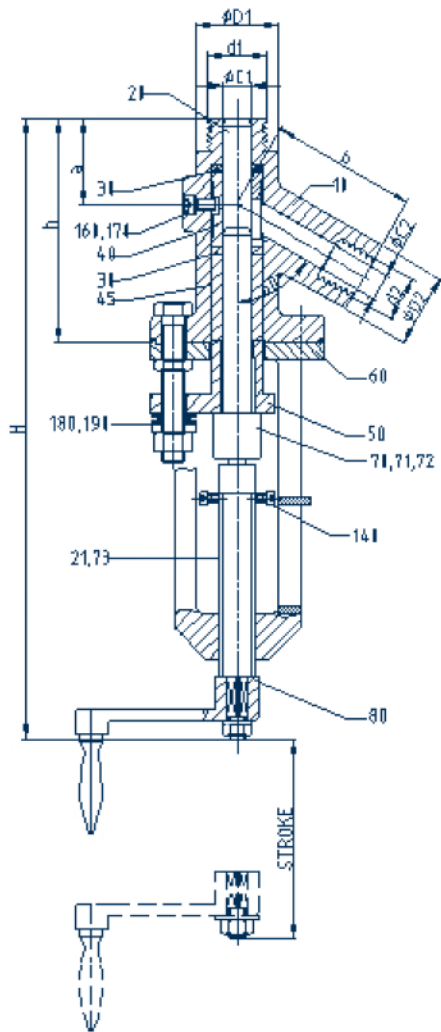
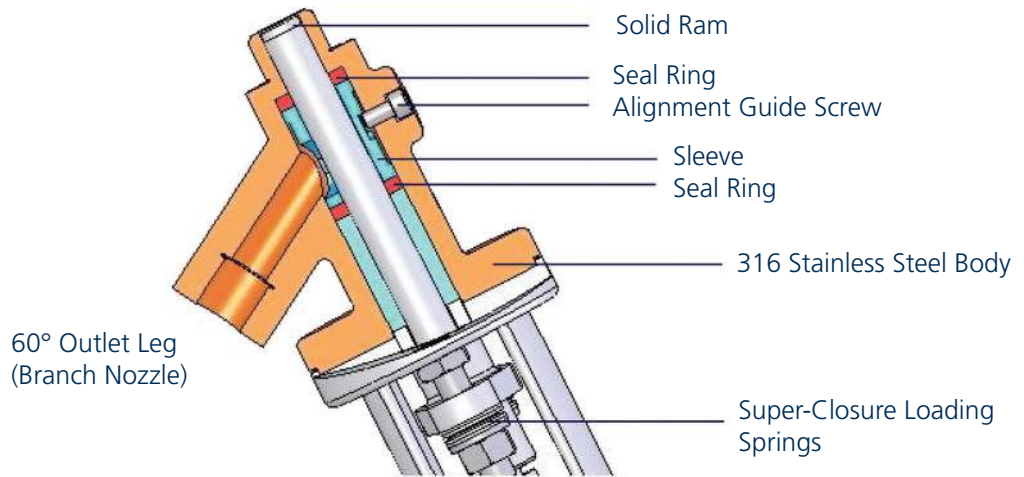

Model 32FR Parts List:

POS NO	DESCRIPTION	MATERIAL	QTY
10	BODY	ASTM GR.CF-8M / 1.4408	1
20	RAM	SS 316 / 1.4401	1
21	SPINDLE	SS416 / 1.4005	1
30	SEALING RING	PTFE / GLASS 25%	2
40	PRESSURE SLEEVE	SS 316 / 1.4401	1
45	GUIDE BUSH	SS 316 / 1.4401	1
50	STUFFING BOX	ASTM GR.CF-8M / 1.4408	1
60	YOKE	SS 303 / 1.4305	1
70	CONNECTING NUT	SS416 / 1.4005	1
71	ROLL / SPRING PIN	CARBON STEEL	1
72	STEM BUTTON	SS TYPE 17-4 PH / 1.4541	1
73	ROLL / SPRING PIN	CARBON STEEL	1
80	CRANK HANDLE	ASTM GR.CF-8 / 1.4308	1
140	INDICATOR	SS 303 / 1.4305	1
160	SOCKET HEAD CAP SCREW	A2-70	1
170	GASKET	FLUOROLOY K	2
180	CUP SPRING	1.4122	8
190	WASHER	A4	2

Dimension Table: (Sizes in inches, others in mm)

SIZE	ØD		d		ØC		a	b	h	H	STROKE
	ØD1	ØD2	NPT	NPT	ØC1	ØC2					
1/2" x 1/2"	45	40	1/2"	1/2"	13	15	47	80	123	345	60
3/4" x 1/2"	45	40	3/4"	1/2"	16	15	47	80	123	345	60
3/4" x 3/4"	45	40	3/4"	3/4"	16	15	47	80	123	345	60
1" x 1/2"	45	40	1"	1/2"	16	15	47	80	123	345	60
1" x 3/4"	45	40	1"	3/4"	16	15	47	80	123	345	60
1 1/2" x 1"	60	45	1 1/2"	1"	25	25	47	90	140	360	65

Max. Temperature:

PTFE Sealing Rings: 200°C

Blue Guard Sealing Rings: 370°C

Pressure Rating:

Valves rated to ASME 600

Model 32PG "Metal Seated Ram" Sampling Valve

FIRE-SAFE TESTED!

60° Outlet Leg
(Branch Nozzle)

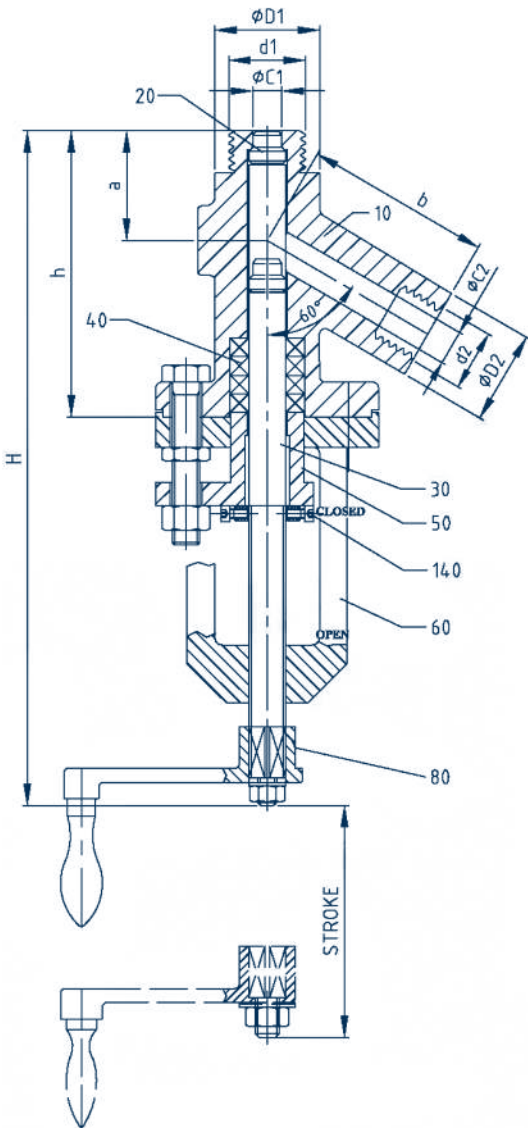
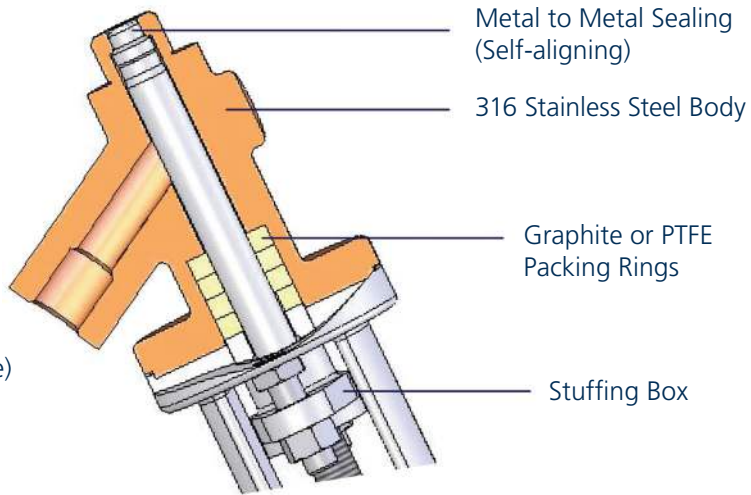

Model 32PG Parts List:

POS NO	DESCRIPTION	MATERIAL	QTY
10	BODY	ASTM GR.CF-8M / 1.4408	1
20	RAM	SS 316 / 1.4401	1
30	SPINDLE	SS 316 / 1.4401	1
40	PACKING RING	PTFE / GRAPHITE	4
50	STUFFING BOX	ASTM GR CF-8M / 1.4408	1
60	YOKE	SS 303 / 1.4305	1
80	CRANK HANDLE	ASTM GR.CF-8 / 1.4308	1
140	INDICATOR	SS 303 / 1.4305	1

Dimension Table: (Sizes in inches, others in mm)

SIZE	ØD1 ØD2		d1 d2		ØC1	ØC2	a	b	h	H	STROKE
	NPT	NPT									
1/2" x 1/2"	45	40	1/2"	1/2"	12.5	15	47	80	123	295	55
3/4" x 1/2"	45	40	3/4"	1/2"	12.5	15	47	80	123	295	55
3/4" x 3/4"	45	40	3/4"	3/4"	12.5	15	47	80	123	295	55
1" x 1/2"	45	40	1"	1/2"	12.5	15	47	80	123	295	55
1" x 3/4"	45	40	1"	3/4"	12.5	15	47	80	123	295	55
1 1/2" x 1"	60	45	1 1/2"	1"	25	25	47	90	140	310	55

Max. Temperature:

PTFE Packing Rings: 260°C
Graphite Packing Rings: 550°C

Pressure Rating:

Valves rated to ASME 600

Model 32FG "Ram Seal"® Sampling Valve

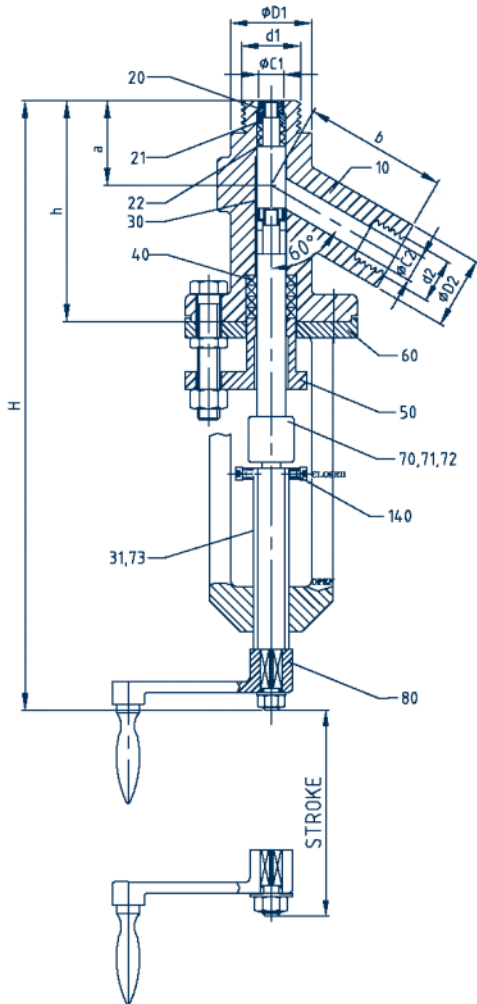
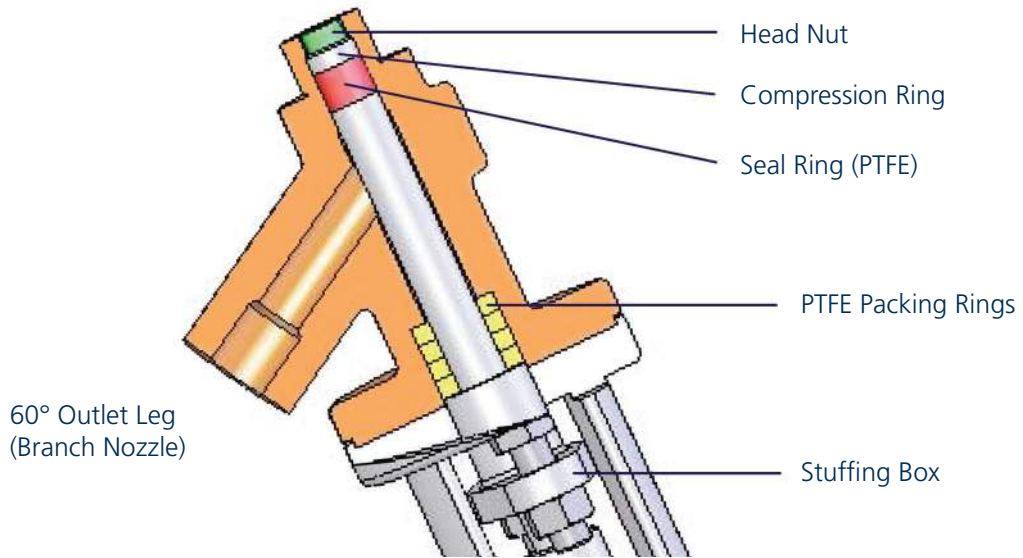

Model 32FG Parts List:

POS NO	DESCRIPTION	MATERIAL	QTY
10	BODY	ASTM GR.CF-8M / 1.4408	1
20	RAM HEAD NUT	SS 316 / 1.4401	1
21	COMPRESSION RING	SS 316 / 1.4401	1
22	SEALING RING	PTFE	1
30	RAM	SS 316 / 1.4401	1
31	SPINDLE	SS416 / 1.4005	1
40	PACKING RING	PTFE / GRAPHITE	4
50	STUFFING BOX GLAND	ASTM GR CF-8M / 1.4408	1
60	YOKE	SS 303 / 1.4305	1
70	CONNECTING NUT	SS416 / 1.4005	1
71	SPRING DOWEL PIN	CARBON STEEL	1
72	STEM BUTTON	SS TYPE 17-4 PH / 1.4541	1
73	SPRING DOWEL PIN	CARBON STEEL	1
80	CRANK HANDLE	ASTM GR.CF-8 / 1.4308	1
140	INDICATOR	SS 303 / 1.4305	1

Dimension Table: (Sizes in inches, others in mm)

SIZE	d1		d2		ØC1	ØC2	a	b	h	H	STROKE
	ØD1	ØD2	NPT	NPT							
1/2" x 1/2"	45	40	1/2"	1/2"	11	15	47	80	123	340	60
3/4" x 1/2"	45	40	3/4"	1/2"	14	15	47	80	123	340	60
3/4" x 3/4"	45	40	3/4"	3/4"	14	15	47	80	123	340	60
1" x 1/2"	45	40	1"	1/2"	14	15	47	80	123	340	60
1" x 3/4"	45	40	1"	3/4"	14	15	47	80	123	340	60
1 1/2" x 1"	60	45	1 1/2"	1"	23	25	47	90	140	360	65

Max. Temperature:
PTFE Sealing Ring: 260°C

Pressure Rating:
Valves rated to ASME 600

Model 32PT "Metal Seated Disc" Sampling Valve

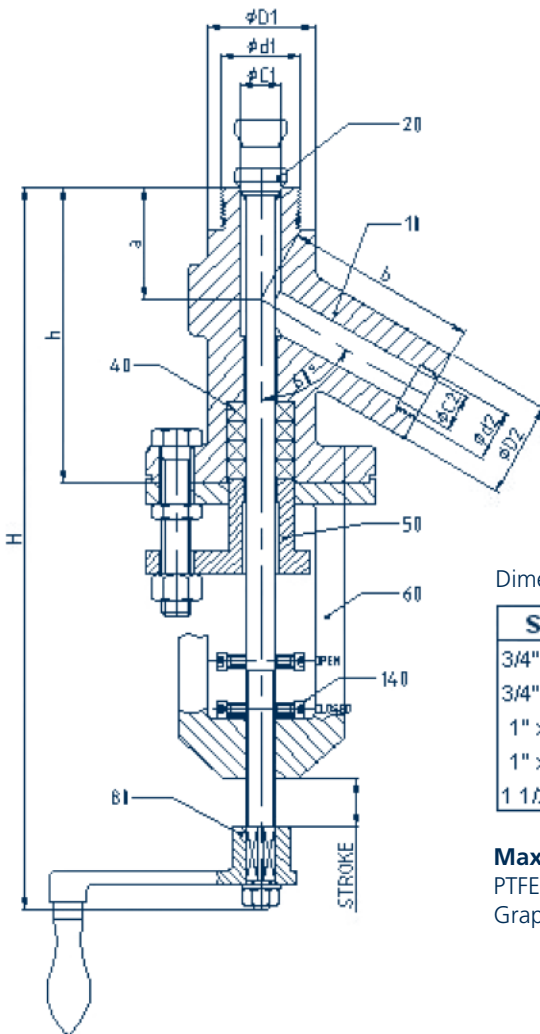
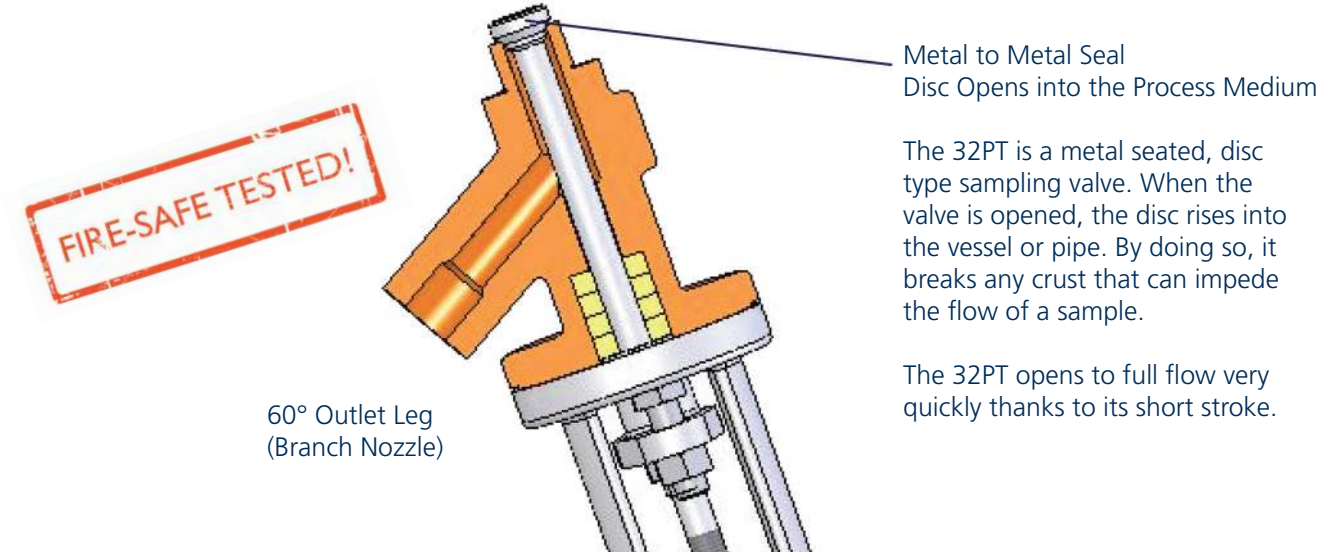

Model 32PT Parts List:

POS NO	DESCRIPTION	MATERIAL	QTY
10	BODY	ASTM GR.CF-8M / 1.4408	1
20	DISC WITH SPINDLE	SS 316 / 1.4401	1
40	PACKING RING	PTFE / GRAPHITE	4
50	STUFFING BOX	ASTM GR CF-8M / 1.4408	1
60	YOKE	SS 303 / 1.4305	1
80	CRANK HANDLE	ASTM GR.CF-8 / 1.4308	1
140	INDICATOR	SS 303 / 1.4305	1

Dimensional Tab: (Sizes in inches, others in mm)

SIZE	ØD1	ØD2	d1 NPT	d2 NPT	ØC1	ØC2	a	b	h	H	STROKE
3/4" x 1/2"	45	40	3/4"	1/2"	17	15	47	80	123	300	20
3/4" x 3/4"	45	40	3/4"	3/4"	17	15	47	80	123	300	20
1" x 1/2"	45	40	1"	1/2"	17	15	47	80	123	300	20
1" x 3/4"	45	40	1"	3/4"	17	15	47	80	123	300	20
1 1/2" x 1"	60	45	1 1/2"	1"	25	25	47	90	140	320	20

Max. Temperature:
 PTFE Packing Rings: 260°C
 Graphite Packing Rings: 550°C

Pressure Rating:
 Valves rated to ASME 600

Model 31PF "Integral Flange" Sampling Valve

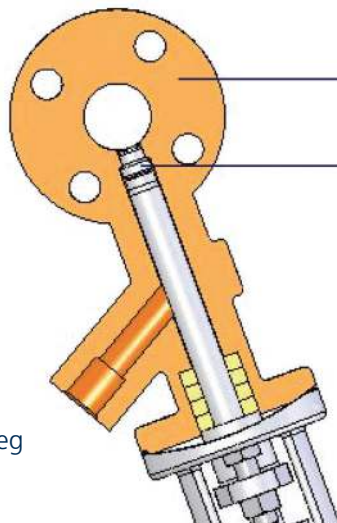

Integral Flange Insert
(Metal Connection Possible)

Metal to Metal Seal (Soft Seals Available)
Flush with ID of Insert / Product Pipe

60° or 45° Outlet Leg
(Branch Nozzle)

These valves are built with a metal insert that is welded to the valve. The complete assembly is installed in the product line (flanged, clamped or welded). The valve seals flush with the inner diameter (ID) of the insert which has the same ID as the product line. Any of the sealing methods shown in the Model 32 drawings (metal or soft seats) can be used in the Model 31PF configuration. In addition to a guaranteed dead space free arrangement, with the Model 31PF, there is no risk of distorting the valve's sealing surfaces during welding and installation work at site.

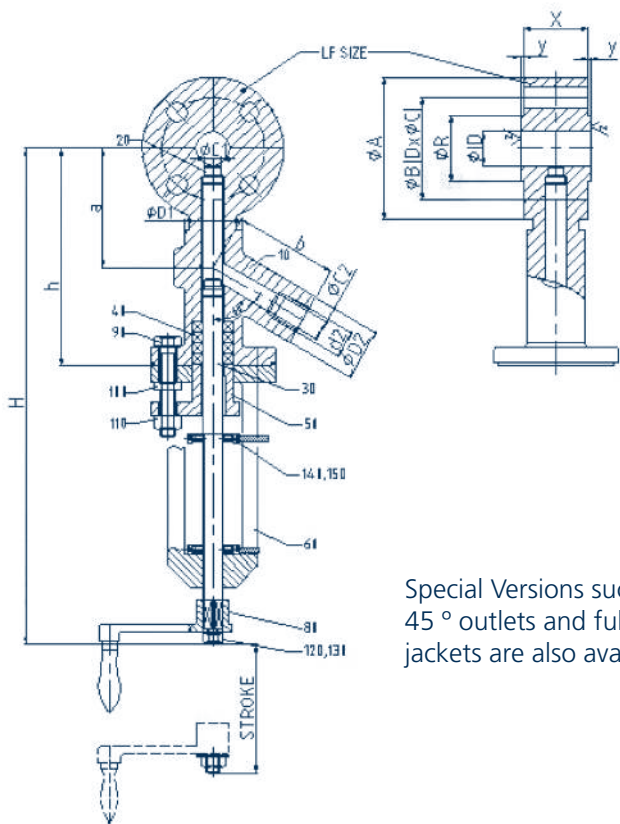

Special Versions such as 45° outlets and full heating jackets are also available.

Model 31PF Parts List:

POS NO	DESCRIPTION	MATERIAL	QTY
10	BODY	ASTM GR. CF-8M / 1.4408	1
20	DISC	SS 316 / 1.4401	1
30	SPINDLE	SS 316 / 1.4401	1
40	PACKING RING	PTFE / GRAPHITE	4
50	STUFFING BOX	ASTM GR. CF-8M / 1.4408	1
60	YOKE	SS 303 / 1.4305	1
80	CRANK HANDLE	ASTM GR. CF-8 / 1.4308	1
140	INDICATOR	SS 303 / 1.4305	1



Max. Temperature:
PTFE Packing Rings: 260°C
Graphite Packing Rings: 550°C

Pressure Rating:
Valves rated to ASME 600

Available insert sizes:

LF SIZE (ANSI) ANSI 150 to 600	1/2"	3/4"	1"	1 1/4"	1 1/2"	2"	2 1/2"	3"	3 1/2"	4"	5"	6"	8"	10"	12"
LF SIZE (DIN) PN 10 to PN 63	DN 10	DN 15	DN 20	DN 25	DN 32	DN 40	DN 50	DN 65	DN 80	DN 100	DN 125	DN 150	DN 200	DN 250	DN 300

Models 30P “Core Pipe Assembly” and 30T “Horizontal Installation”

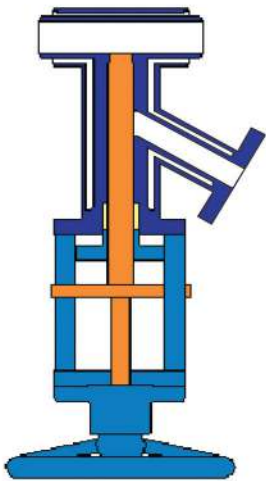

Model 30P

Model 30P valves are also known as core pipe assemblies. They allow the user to take a sample under high temperature and pressure. The valve is welded to a spool piece which is a short piece of the process pipe. The valve assembly is welded directly into the process piping. In polymer applications, the 30P is usually fully jacketed. The spool piece connections can have weld, Grayloc™ or flanged ends.

The 30P can also be used to drain a line in a shut-down situation, to flush or purge it or as an injection valve.



Model 30T – Tangential Sampling with contoured Ram

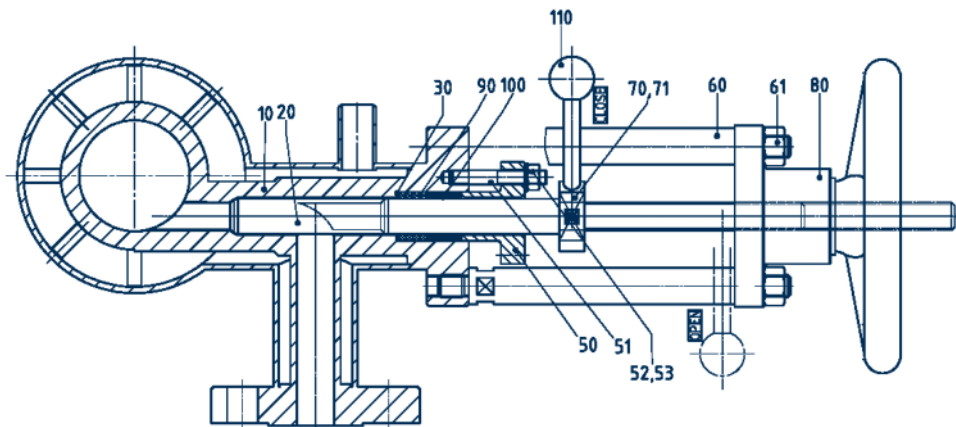

Another SchuF innovation, the 30T, allows the valve to be installed horizontally. This enables the operator to take a vertical sample without having to operate the valve under the pipe – a potentially dangerous situation should hot polymer splash or spill while the sample is being taken.

All Model 30 valves are custom-built assemblies. Options include a wide variety of metallurgies, actuators, pressure ratings from full vacuum to ASME 2500 / PN 400, hardened sealing surfaces and replaceable seats.

Additional Sampling Valve Options

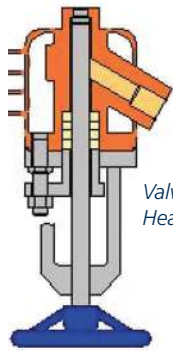

Valve with Heating Jacket

All SchuF Fetterolf sampling valves can be jacketed. Heating jackets cover the entire valve body fully, and they also heat the packing area. They are welded to the body. Unlike clamp-on jackets, there are no cold spots, this way making them ideal for difficult media such as high temperature polymers.

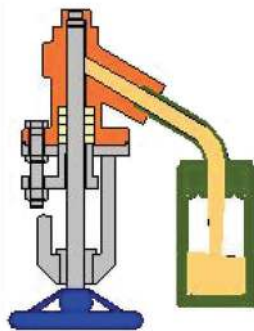

Valve with Sampling Bottle

All SchuF Fetterolf sampling valves can be supplied with sample bottles. High temperature metal containers are also available.

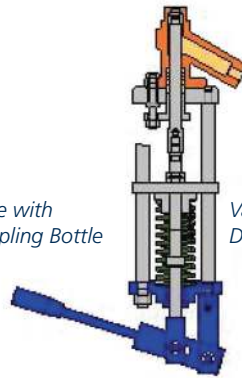

Valve with Deadman's Handle

This spring-loaded operator ensures that manual valves close very fast and automatically as soon as the handle is released.

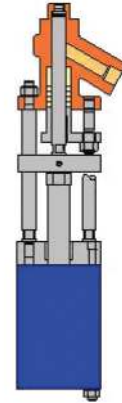

Valve with Piston Actuator

All Sampling Valves can be delivered with double acting or spring return pneumatic piston actuators as well as instrumentation accessories.

Solutions for Critical Applications

Sampling Systems:

SchuF Fetterolf offers complete sampling valve solutions which may include features such as fixed volume sampling with high pressure sampling containers complete with vent valves. Vacuum ports help draw samples, and purge connections ensure the system is clean after the sampling valve is closed.

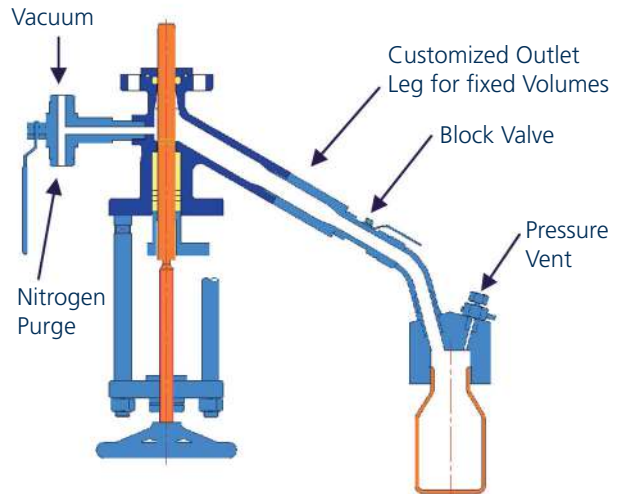

Lethal Service:

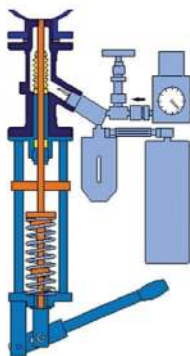

The 32PH has a metal bellows seal for zero leakage to the atmosphere. Options include leak detection chambers and venting canisters.

An emergency stuffing box enables the valve to maintain zero leakage through the gland should the bellows break.

The 32 Powder Sampling Valve is mounted horizontally. When the ram is extended into the vessel or pipe, the sampling cavity in the ram will fill with medium. To retrieve the sample, retract the ram back fully into the valve, then turn the lever 180° to rotate the sampling cavity directly over the valve outlet. The powder sample will then drop into the sample bottle.

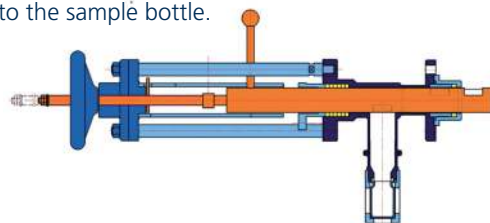

SchuF Fetterolf Sampling Valve - Please specify your inquiry:

CONTACT INFORMATION:

Name:
 Company:
 City:
 Country/State:
 Phone:
 Fax:
 E-Mail:

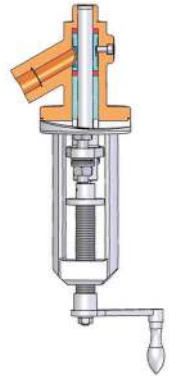

MODEL/QUANTITY:

Please choose: Quantity:
 32FR (Rod Seal®):
 32PG (Metal to Metal Seal):
 32FG (Ram Seal®):
 Other, including custom Solution:

MATERIALS:

Wetted Parts: 316 stainless (standard) or other:
 Medium/Temperature / Pressure:

HEATING JACKET:

Yes or No:
 Heating Medium:
 Temperature & Pressure:
 Jacket Connections:

ACTUATION:

Crank Handle (Standard)
 Handwheel:
 Deadman's Handle:
 Pneumatic, Spring Return or Double-acting:
 Accessories (Solenoid Valves, Limit Switches etc.):

CONNECTIONS (Inlet & Outlet):

Rating & Size:
 Threaded / ① Flanged / Weld Socket / Other:
 ② T-Piece (please specify Pipe Size, Material & Rating):
 ③ Half-Coupling (please specify Pipe Size, Material & Rating):
 ④ Valve Body with Flushing Port (Yes or No):
 ⑤ Ram Extension / ⑥ Fixed Seat (x & d1 - Dimensions):
 ⑦ Extended Body / Seat (x & d1 - Dimensions):
 ⑧ Extended Body / Seat & extra Ram Extension (x & d1 & p - Dimensions):
 Other Accessories (e.g. Sampling Bottle etc.):

OPTIONS: Extended Rams & Bodies, different Valve Connections



① Flange Connection

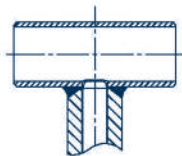

② T-Piece



③ Contoured Half-Coupling
(can also be non-contoured)

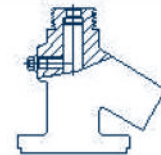

④ Flushing Port

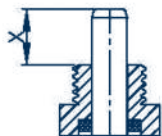

⑤ Ram Extension

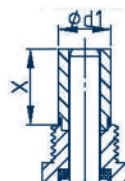

⑥ Fixed Seat

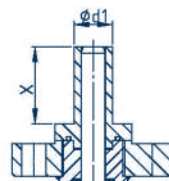

⑦ Extended Body / Seat

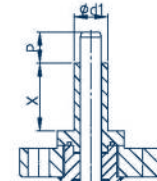

⑧ Extended Body / Seat & extra
Ram Extension &

SchuF Worldwide

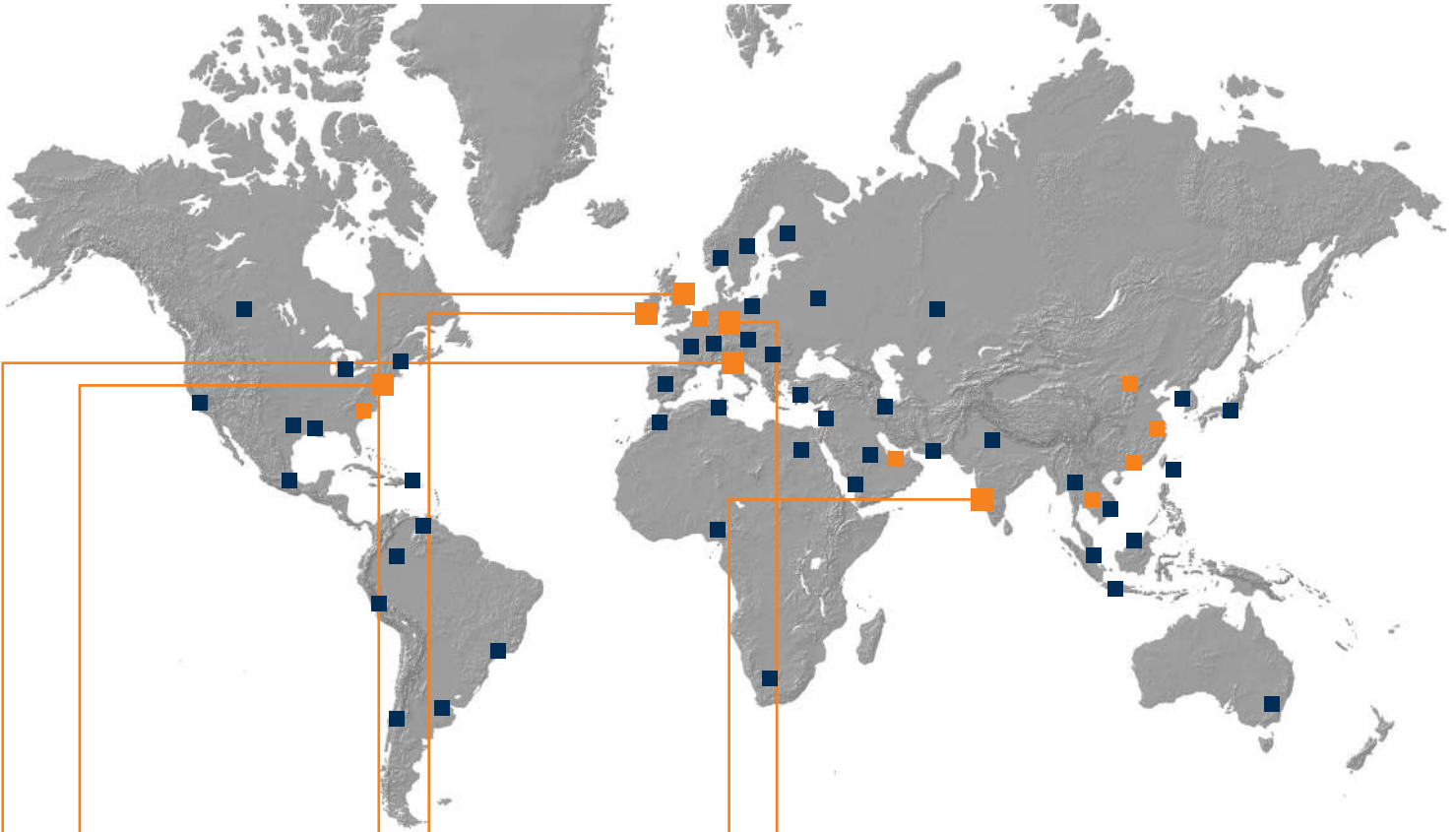

www.schuf.com

www.schuf.de

USA



Fetterolf Corporation
phone: +1 610 584-1500
info@fetterolfvalves.com

SchuF (USA) Inc.
phone: +1 843 881 3345
sales@schuf.us

IRELAND



SchuF Valve Technology GmbH
phone: +353 21 4837000
sales@schuf.ie

GERMANY



**SchuF-Armaturen
und Apparatebau GmbH**
phone: +49 6198 571 100
sales@schuf.com

Your Sales Channel:

SchuF Benelux B.V.
phone +31 25 12 34 448
lmulder@schuf.com

SchuF Middle East F.Z.C.
phone: 971 56 424 2190
mmulder@schuf.com

SchuF South East Asia Pte. Ltd.
phone +353 877774860
ecalnan@schuf.ie

SchuF Valves China Ltd.
phone +85 22 86 50 861
pchoi@schuf.com

ITALY



La Tecnovalvo S.r.l.
phone: +39 023503508
info@latecnovalvo.com

UNITED KINGDOM



SchuF (UK) Ltd.
phone: +44 203 355 2012
sales@schuf.ie

INDIA



**SchuF Speciality Valves
India Pvt. Ltd.**
phone: +91 421 2264600
sales@schuf-india.com

Your Local Agent: